

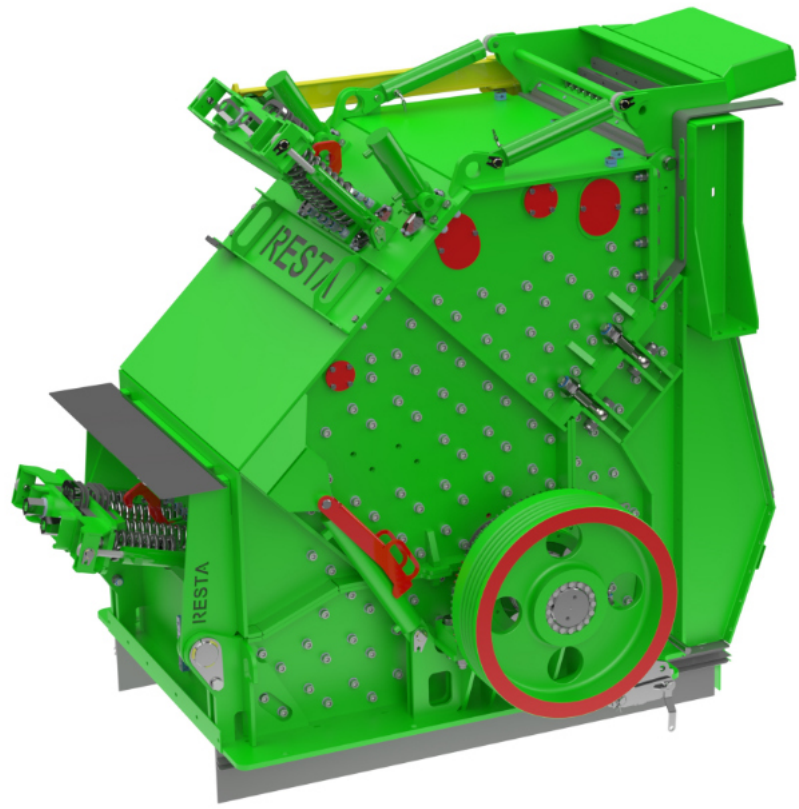

HORIZONTAL IMPACT CRUSHERS

Advantages

- ✓ high performance
- ✓ easy replacement of crushing elements
- ✓ excellent shape index
- ✓ high degree of crushing ratio
- ✓ easy operation and maintenance
- ✓ option to use ceramic bars for long lifetime



| Type | Inlet [mm] | Max. piece [mm] | Max. output [t/h] | El. motor [kW] | Weight [t] |
|--------------|------------|-----------------|-------------------|----------------|------------|
| OD 1050x500 | 550x680 | 500 | 110 | 110 | 6 |
| OD 1050x1000 | 1040x640 | 600 | 205 | 160 | 10,5 |
| OD 1300x1600 | 970x1650 | 1000 | 300 | 200-400 | 19,5 |
| OD 1600x1600 | 1250x1650 | 1500 | 460 | 315-360 | 38 |

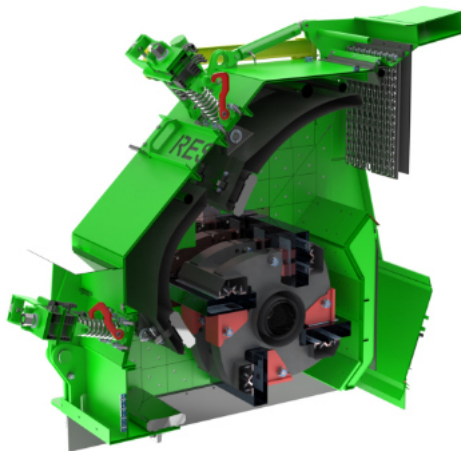
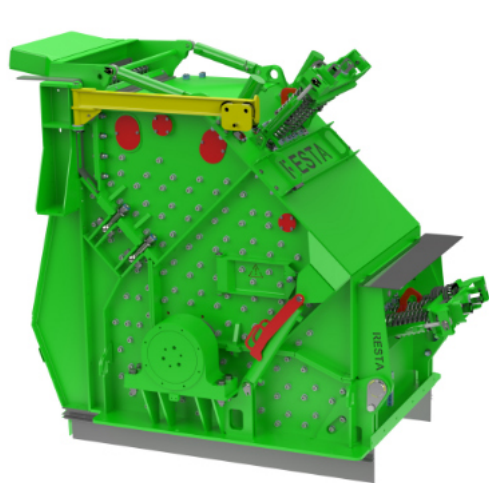

RESTA s.r.o.
CRN: 14616807
TIN: CZ 14616807

Kojetínská 3120/75
750 02 Přerov
Czech Republic

✉ resta@resta.cz
☎ +420 581 741 811

www.resta.cz